

EE6503 POWER ELECTRONICS
UNIT-1 POWER SEMI-CONDUCTOR DEVICES

1. What are the different methods to turn on the thyristor?

Voltage Thyristor Triggering:
Thermal Thyristor Triggering: Light
Thyristor Triggering: dv/dt
triggering:
Gate triggering:

2. Define latching current.

It is the min current required for the device to conduct even without a gate signal .

3. Define holding current.

It is the minimum current which must pass through a circuit in order for it to remain in the 'ON' state. The term can be applied to a single switch or to an entire device.

4. What is a snubber circuit?

Snubber circuits are required to limit dt/di , dt/dv and overvoltage during turn-on and turnoff.

5. What is the difference between power diode and signal diode?

Constructed with n-layer, called drift region between p+ layer and n+ layer. The voltage, current and power ratings are higher.

Power diodes operate at high speeds. Drift region is not present. Operates at higher switching speed.

6. What is the need of driver circuit?

A driver is an electrical circuit or other electronic component used to control another circuit or component, such as a high-power transistor, liquid crystal display (LCD), and numerous others.

7. Why are IGBT becoming popular in their application to controlled converters?

IGBT have low ON state losses

IGBT has high switching frequencies compared to thyristors. Do not require any commutation circuits.

8. What are the factors that influence the turn-off time of a thyristor?

The doping levels of various regions.

The width of the regions and voltage blocking capability.

9. Define the term pinch off voltage of MOSFET.

When gate source is reverse biased in n-channel MOSFET the channel is depleted, A pinch-off voltage is the reverse gate source voltage at which the channel is completely depleted and no drain current flows through the channel.

10. How a thyristor can be protected against excess dv/dt ?

A minimum time is required for the thyristor to spread the current conduction uniformly throughout the junctions. If this time is not allotted and the rate of rise of anode current is very high compared to the spreading velocity at turn-on, then this could lead to localised "hot-spot" heating and the device may fail as a result of excessive heating.

11. In TRIAC which of the modes the sensitivity of gate is high.

The relative sensitivity depends on the physical structure of a particular triac, but as a rule, quadrant I is the most sensitive (least gate ... In most applications, the gate current comes from MT2, so quadrants 1 and 2 are the only operating modes. A high rate of rise of the current between MT1 and MT2 .

12. How SCR differs from TRIAC?

A thyristor, also known as a silicon controlled rectifier (SCR) is a uni-directional device. Under normal operating circumstances, it will pass current in one direction, only A triac is a bi- directional device. It will pass current in both directions, thus it may be used to switch alternating current (AC)

13. State the advantages of IGBT over MOSFET.

It has a very low on-state voltage drop due to conductivity modulation and has superior on-state current density. So smaller chip size is possible and the cost can be reduced. 2. Low driving power and a simple drive circuit due to the input MOS gate structure. It can be easily controlled as compared to current controlled devices (thyristor, BJT) in high voltage and high current applications. 3. Wide SOA. It has superior current conduction capability compared with the bipolar transistor. It also has excellent forward and reverse blocking capabilities.

14. Draw the VI characteristics of TRIAC.

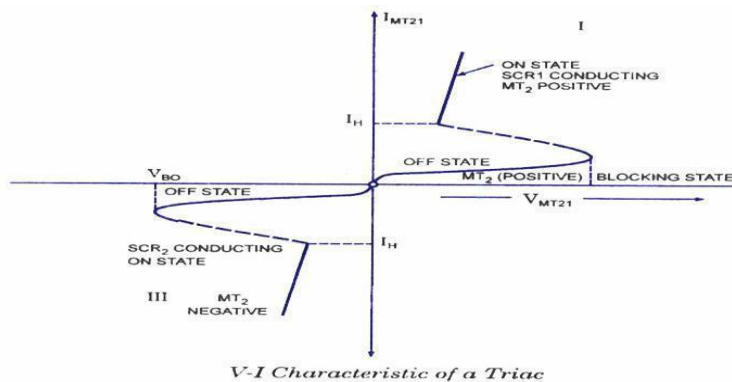

15. What is commutation? What are the two main types of commutation?.

- Class A Self commutated by a resonating load
- Class B Self commutated by an L-C circuit
- Class C C or L-C switched by another load carrying SCR
- Class D C or L-C switched by an auxiliary SCR
- Class E An external pulse source for commutation
- Class F AC line commutation

17. Define turn-on time and turn-off time of thyristor.

A forward biased thyristor can be turned on by applying a positive voltage between gate and cathode terminal. But it takes some transition time to go from forward blocking mode to forward conduction mode. This transition time is called turn on time of SCR

Turn off time of SCR can be defined as the interval between anode current falls to zero and device regains its forward blocking mode. On the basis of removing carrier charges from the four layers,

18. Define PIV and reverse recovery time of Power diodes.

When the diode switches from conducting to non-conducting state. Where in a p-n diode the reverse recovery time can be in the order of hundreds of nanoseconds and less than 100 ns for fast diodes, Schottky diodes do not have a recovery time, as there is nothing to recover.

19. What are the drawbacks of GTO?

- Magnitude of latching, holding currents is more. The latching current of the GTO is several times more as compared to conventional thyristors of the same rating.
- On state voltage drop and the associated loss is more.
- Due to multicathode structure of GTO, triggering gate current is higher than that required for normal SCR.
- Gate drive circuit losses are more. Its reverse voltage blocking capability is less than the forward voltage blocking capability.

20. Draw the turn on characteristics of TRIAC and mark the timings t_d , t_r and t_{on}

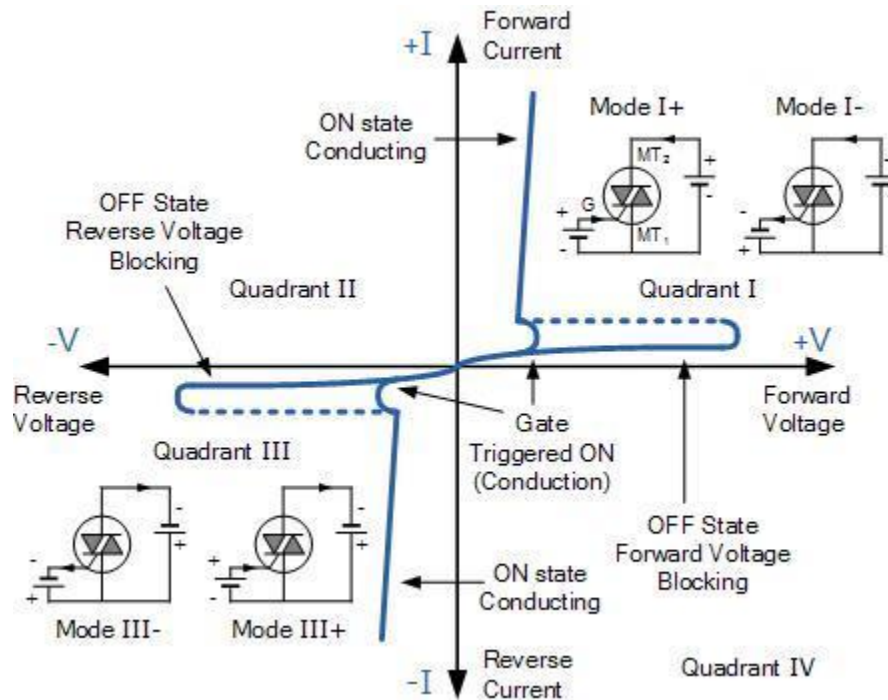

UNIT II PHASE-CONTROLLED CONVERTERS

1. What is the function of freewheeling diodes in controlled rectifier?

A "freewheeling diode" is put into a circuit to protect the switching device from being damaged by the reverse current of an inductive load. It is normally placed in a circuit so that it does not conduct when the current is being supplied to the inductive load.

2. What is commutation angle or overlap angle?

The commutation period when outgoing and incoming thyristors are conducting is known as overlap period. The angular period, when both devices share conduction is known as the commutation angle or overlap angle

3. What are the advantages of six pulse converter?

- a. Commutation is made simple.
- b. Distortion on the ac side is reduced due to the reduction in lower order harmonics.
- c. Inductance reduced in series is considerably reduced.

4. What is meant by commutation?

It is the process of changing the direction of current flow in a particular path of the circuit. This process is used in thyristors for turning it off.

5. What are the types of commutation?

- a. Natural commutation
- b. Forced commutation

6. Mention some of the applications of controlled rectifier.

- a. Steel rolling mills, printing press, textile mills and paper mills employing DC motor drives.
- b. DC traction
- c. Electro chemical and electro-metallurgical process
- d. Portable hand tool drives
- e. Magnet power supplies
- f. HVDC transmission system

7. What are the different methods of firing circuits for line commutated converter?

- a. UJT firing circuit.
- b. The cosine wave crossing pulse timing control.
- c. Digital firing schemes.

8. What are the advantages of three phase converter over single phase converter?

- Three phase power distribution requires lesser amount of copper or aluminium for transferring the same amount of power as compared to single phase power
- The size of a three phase motor is smaller than that of a single phase motor of the same rating.
- Three phase motors are self starting as they can produce a rotating magnetic field. The single phase motor requires a special starting winding as it produces only a pulsating magnetic field.
- The ripple factor of rectified dc produced from three phase power is less than the dc produced from single phase supply.
- Three phase motors have better power factor regulation.
- Three phase generators are smaller in size than single phase generators as winding phase can be more efficiently used.

9. What is meant by forced commutation?

In this commutation, the current flowing through the thyristor is forced to become zero by external circuitry

10. What is meant by natural commutation?

Here the current flowing through the thyristor goes through a natural zero and enable the thyristor to turn off.

11. What is meant by natural and forced commutation?

Natural commutation

Here the current flowing through the thyristor goes through a natural zero and enable the thyristor to turn off.

Forced commutation:

In this commutation, the current flowing through the thyristor is forced to become zero by external circuitry

12. Write the expression for output DC voltage in a single phase fully controlled half converter.

$$V_{dix} = \frac{1}{\pi} \int_{\alpha}^{\pi} V_{\max} \sin \omega t d(\omega t) = \frac{V_{\max}}{\pi} (1 + \cos \alpha)$$

13. Draw the circuit diagram of single phase dual converter.

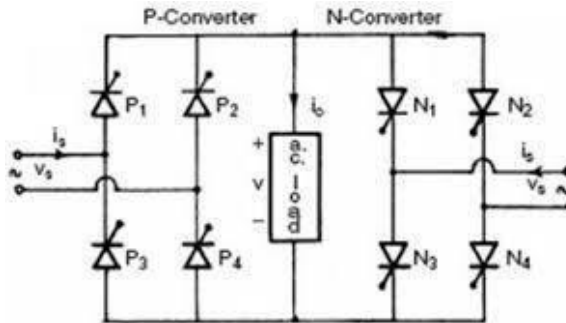

14. Give any two differences between single phase full converter and semi converter.

Fully controlled rectifier uses only SCR's Negative output voltages are obtained two quadrant control wide range control costly semi converter uses diodes and SCR's only positive output voltages are obtained one quadrant control only positive half cycles are controlled.

15. What is meant by phase control?

In this method, thyristor switches connect the load to the ac source for a portion of each half cycle of input voltage.

16. Compare half controlled rectifier and full controlled rectifier.

S.no	Half controlled	Full controlled
1	Uses un controlled element (diodes)	Uses controlled element switches
2	Output voltage is constant	adjustable

17. What is dual converter?

The fully controlled converter can produce a reversible direct output voltage with output current in one direction, and in terms of a conventional voltage/ current is said to be capable of operation in two quadrants, the first and fourth

18. Write the expression for output dc voltage in a single phase fully controlled full converter for RL load

$$V_{dix} = \frac{1}{\pi} \int_{\alpha}^{\pi+\alpha} V_{\max} \sin \omega t d(\omega t) = \frac{2V_{\max}}{\pi} \cos \alpha$$

19. Define Total Harmonic Distortion (THD).

The total harmonic distortion, or THD, of a signal is a measurement of the harmonic distortion present and is defined as the ratio of the sum of the powers of all harmonic components to the power of the fundamental frequency.

20. Define ripple factor

Ripple factor (γ) may be defined as the ratio of the root mean square (rms) value of the ripple voltage to the absolute value of the dc component of the output voltage, usually expressed as a percentage. However, ripple voltage is also commonly expressed as the peak-to-peak value.

UNIT III DC TO DC CONVERTER

PART-A

1. What is meant by dc chopper?

A dc chopper is a high speed static switch used to obtain variable dc voltage from a constant dc voltage.

2. What are the advantages and applications of dc chopper?

Chopper provides

- a. High efficiency
- b. Smooth acceleration
- c. Fast dynamic response
- d. Regeneration

3. Applications of DC Chopper:

- a. Battery operated vehicles
- b. Traction motor control in electric traction
- c. Trolley cars
- d. Marine hoists
- e. Mine haulers
- f. Electric braking.

4. What is meant by step-up and step-down chopper?

In a step- down chopper or Buck converter, the average output voltage is less than the input voltage. In a step- up chopper or Boost converter, the average output voltage is more than the input voltage.

5. What is meant by duty-cycle?

Duty cycle is defined as the ratio of the on time of the chopper to the total time period of the chopper. It is denoted by 'D'.

$D = \frac{T_{ON}}{T}$, where T_{ON} → on time period of chopper

T → total time period $T = T_{ON} + T_{OFF}$

6. What are the two types of control strategies?

- a. Time Ratio Control (TRC)
- b. Current Limit Control method (CLC)

7. What is meant by TRC? And what are the two types of TRC?

In Time Ratio Control TRC, the value of T_{on} / T is varied in order to change the average output voltage.

Types of TRC:

- a. Constant frequency control
- b. Variable frequency control

8. What is meant by PWM control in dc chopper?

In this control method, the on time T_{on} is varied but chopping frequency is kept constant.

The width of the pulse is varied and hence this type of control is known as Pulse Width Modulation (PWM).

9. What are the advantages of PWM control?

- a. The output voltage can be obtained without any additional components.
- b. Lower order harmonics can be eliminated or minimized along with its output voltage control. As the higher order harmonics can be filtered easily, the filtering requirements are minimized.

10. What is meant by load commutation?

In this process, the load current flowing through the thyristor either becomes zero or is transferred to another device from the conducting thyristor

11. What is constant frequency control of chopper?

In this control method, the on time T_{on} is varied but chopping frequency is kept constant. The width of the pulse is varied and hence this type of control is known as constant frequency control or Pulse Width Modulation (PWM)

12. What are the different techniques of PWM techniques?

- i. Single- pulse modulation
- ii. Multiple- pulse modulation
- iii. Sinusoidal pulse modulation

13. What are the different types of commutation available?

- a. Natural commutation
- b. Forced commutation

14. Mention the disadvantages of PWM.

A disadvantage of PWM dc-dc converters is that PWM rectangular voltage and current waveforms cause turn-on and turn-off losses in semiconductor devices, which limit practical operating frequencies to hundreds of kilohertz. Rectangular waveforms also inherently generate EMI.

15. What is meant by SMPS?

A SMPS is based on DC chopper with a rectified and possibly transformed output. By operating the on/off switches vary rapidly, AC ripple frequency raises which can be easily filtered by L and C filter. This filter size also reduces. Due to this, SMPS is very popular in all applications

16. Define ZVS & ZCS?

ZVS:

Zero Voltage Switching means that the power to the load (heater or cooler or other device) is switched on or off only when the output voltage is zero volts.

ZCS:

Zero current Switching means that the power to the load (heater or cooler or other device) is switched on or off only when the output current is zero ampere

17. What are the types of chopper?

- a. Type A or Class – A chopper
- b. Type B or Class –B chopper
- c. Type C or Class –C chopper
- c. Type D or Class – D chopper
- d. Type E or Class – E chopper

18. Draw the circuit diagram of four quadrant chopper

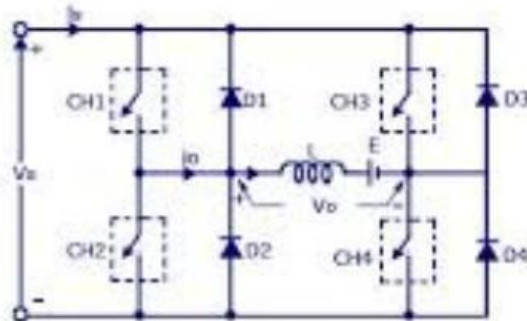

19. Mention the mode of operation in dual converter. The functional modes of dual converter are,

- 1. Non- circulating current mode
- 2. Circulating current mode

20. What is meant by resonant converters?

The converter circuits, which employ zero-voltage and or zero current switching, are called resonant converters.

UNIT IV INVERTERS

1. What is meant by inverter?

A device that converts dc power into ac power at desired output voltage and frequency is called an inverter.

2. What are the applications of an inverter?

- i. Adjustable speed drives
- ii. Induction heating

- iii. Stand-by aircraft power supplies
- iv. UPS
- v. HVDC transmission

3. What are the main classifications of inverter?

- a. Voltage Source Inverter
- b. Current Source Inverter

4. Why thyristors are not preferred for inverters?

Thyristors require extra commutation circuits for turn off which results in increased complexity of the circuit. For these reasons thyristors are not preferred for inverters.

5. Give two advantages of CSI

- a. Current Source Inverter does not require any feedback diodes.
- b. Commutation circuit is simple as it involves only thyristors.

6. What is meant by series inverter?

An inverter in which the commutating elements are connected in series with the load is called a series inverter

7. What is meant by parallel inverter?

An inverter in which the commutating elements are connected in parallel with the load is called a parallel inverter.

8. What are the applications of a series inverter?

The thyristorised series inverter produces an approximately sinusoidal waveform at a high output frequency, ranging from 200 Hz to 100kHz. It is commonly used for fixed output applications such as

- a. Ultrasonic generator.
- b. Induction heating.
- c. Sonar Transmitter
- d. Fluorescent lighting.

9. What is meant by McMurray inverter?

It is an impulse commutated inverter which relies on LC circuit and an auxiliary thyristor for commutation in the load circuit.

10. What are the applications of a CSI?

- i. Induction heating
- ii. Lagging VAR compensation
- iii. Speed control of ac motors
- iv. Synchronous motor starting

11. What is meant by PWM control in inverter?

In this method, a fixed dc input voltage is given to the inverter and a controlled ac output voltage is obtained by adjusting the on and off periods of the inverter components. This is the most popular method of controlling the output voltage and this method is termed as PWM control

VSI	CSI
VSI is fed from a DC voltage source having small negligible impedance.	CSI is fed with adjustable current from a DC voltage source of high impedance.
Input voltage is maintained constant	The input current is constant but adjustable.
Output voltage does not depend on the load	the amplitude of output current is independent of the load.

The waveform of the load current as well as its magnitude depends upon the nature of load impedance	The magnitude of output voltage and its waveform depends upon the nature of the load impedance.
---	---

13. What are the advantages of 120 degree mode of operation over 180 degree mode of operation?

We can get continuous conduction in 180 degree mode, whereas discontinuous current flow in 120 degree mode. Hence losses are high in 120 degree mode.

14. List the disadvantages of PWM control.

1. Cost of integrated circuit packages for PWM
2. Complexity of circuitry necessary for implementation
3. Radio Frequency Interference/Electromagnetic Interference limits the performance of the circuitry
4. Voltage spikes in the pulse signal to a rapid succession of switches similar to an impulse

15. What are the applications of a CSI?

The applications of a CSI are,

Induction heating
Lagging VAR
compensation Speed
control of ac motors
Synchronous motor
starting.

16. What is integral cycle control?

Action by a control mechanism that makes changes to the inputs of a manufacturing process based on the accumulated error over a period of time. Integral action controllers are often used in conjunction with proportional controllers, which make corrective changes in proportion to the amount of error in an input, in order to make input adjustments faster and more accurate.

17. List the various advantages of using PWM control in inverter.

1. Average value proportional to duty cycle, this dependence is often observed to follow a linear trend due to the previous formulaic definition.
2. Low power used in transistors used to switch the signal, and fast switching possible due to MOSFETS and power transistors at speeds in excess of 100 kHz
3. Alleviates the problem of high heat losses through resistive elements at intermediate voltage points

18. What are the applications of ac voltage controllers?

- Domestic and industrial heating
- Lighting control
- Speed control of single phase and three phase ac motors
- Transformer tap changing
-

19. Mention the difference between Sinusoidal PWM over modified PWM techniques.

In sinusoidal pulse width modulation there are multiple pulses per half-cycle and the width of each pulse is varied with respect to the sine wave magnitude. Fig 4(c) shows the gating signals and output voltage of SPWM with unipolar switching. In this scheme, the switches in the two legs of the full-bridge inverter are not switched simultaneously, as in the bi-polar scheme

20. Define Space Vector Modulation

Space vector modulation (SVM) is an algorithm for the control of pulse width modulation (PWM). It is used for the creation of alternating (AC) waveforms; most commonly to drive 3 phase AC powered

motors at varying speeds from DC using multiple class-D amplifiers. There are various variations of SVM that result in different quality and computational requirements.

UNIT V AC TO AC CONVERTERS

1. What does ac voltage controller mean?

It is device which converts fixed alternating voltage into a variable voltage without change in frequency.

2. What are the applications of ac voltage controllers?

a. Domestic and industrial heating b. Lighting control c. Speed control of single phase and three phase ac motors d. Transformer tap changing

3. What are the advantages and disadvantages of ac voltage controllers?

Advantages :

a. High efficiency b. Flexibility in control c. Less maintenance

Disadvantages:

The main drawback is the introduction of harmonics in the supply current and the load voltage waveforms particularly at low output voltages.

4. What are the two methods of control in ac voltage controllers?

a. ON-OFF control
b. Phase control

5. What is the difference between ON-OFF control and phase control?

ON-OFF control: In this method, the thyristors are employed as switches to connect the load circuit to the source for a few cycles of the load voltage and disconnect it for another few cycles.

Phase control: In this method, thyristor switches connect the load to the ac source for a portion of each half cycle of input voltage.

6. What is meant by cyclo-converter?

It converts input power at one frequency to output power at another frequency with one-stage conversion. Cyclo converter is also known as frequency changer.

7. What is meant by step-up cyclo-converters?

In these converters, the output frequency is less than the supply frequency.

8. What is meant by step down cyclo-converters?

In these converters, the output frequency is more than the supply frequency.

9. What are the types and applications of cyclo-converter?

Types:

a. Step-up cyclo-converters b. Step-down cyclo-converters

Applications:

a. Induction heating b. Speed control of high power ac drives c. Static VAR generation d. Power supply in aircraft or ship boards

10. What is a Matrix converter?

A three-phase matrix converter converts AC voltages of predetermined amplitude and frequency into AC voltages of any amplitude and frequency and a method for operating the same, include four-segment switches as main switches which are combined into three switch groups

11. Enumerate some of the industrial applications of cyclo converters.

Cyclo converters are used for driving mine hoists, rolling mill main motors, ball mills for ore processing, cement kilns, ship propulsion systems, slip power recovery wound-rotor induction motors (i.e., Scherbius drives) and aircraft 400 Hz power generation.

12. Compare step up and step down cyclo converter. Step up:

In these converters, the output frequency is less than the supply frequency.

Step down:

In these converters, the output frequency is more than the supply frequency.

13. Write down the expression for single phase and three phase RMS output voltage of single phase and three phase cyclo converter?

$$V_o = V_{do} \cos \alpha = V_{do} (E_r/E_m) \sin(\omega_o t - \phi)$$

$$V_{or} = V_{oN} = V_{oP} = rV_{ph} \frac{p}{\pi} \sin \frac{\pi}{p}$$

14. Write down the expression for single phase AC voltage controller with RL load?

$$V_o = \left[\frac{1}{\pi} \int_{\alpha}^{\pi} 2V_s^2 \sin^2 \omega t d(\omega t) \right]^{1/2} = V_s \left[1 - \frac{\alpha}{\pi} + \frac{\sin 2\alpha}{2\pi} \right]^{1/2}$$

15. Write down the expression for single phase AC voltage controller with RLE load?

$$V_o = V_s \left[1 - \frac{3\alpha}{2\pi} + \frac{3}{4\pi} \sin 2\alpha \right]^{1/2}$$

16. Compare single phase cyclo converter over three phase cyclo converter.

The Cycloconverter has been traditionally used only in very high power drives, usually above one megawatt, where no other type of drive can be used. The reasons for this are that the traditional cycloconverter requires a large number of thyristors.

Two three-phase half-wave (three-pulse) converters connected back to back for each phase, with three thyristors for each bridge, are needed here. The total number of thyristors used is 18, thus reducing the cost of power components, and also of control circuits needed to generate the firing pulses for the thyristors

17. Write the output RMS voltage for single phase AC voltage controller with resistance load.

$$V_o = \left[\frac{1}{\pi} \int_{\alpha}^{\beta} 2V_s^2 \sin^2 \omega t d(t) \right]^{1/2}$$
$$= \frac{V_s}{\pi} \left[\beta - \alpha + \frac{\sin 2\alpha}{2} - \frac{\sin 2\beta}{2} \right]^{1/2}$$

18. What is the control range of firing angle in AC voltage controller with R-L load.

The control range of firing angle depends on the type of load. Since it is RL load the firing angle lies between the range of 90 to 120 degree.

19. Define Multistage sequence Control.

If continuous voltage control over a wide range with low harmonic content and improved power factor is required then a large number of stages will have to be used in multi stage sequence control.

20. What is integral cycle control?

In phase control the Thyristors are used as switches to connect the load circuit to the input ac supply, for a part of every input cycle. That is the ac supply voltage is chopped using Thyristors during a part of each input cycle.

